

VERROU VERVELLE À PATTES ET PORTE-CADENAS

ITAR

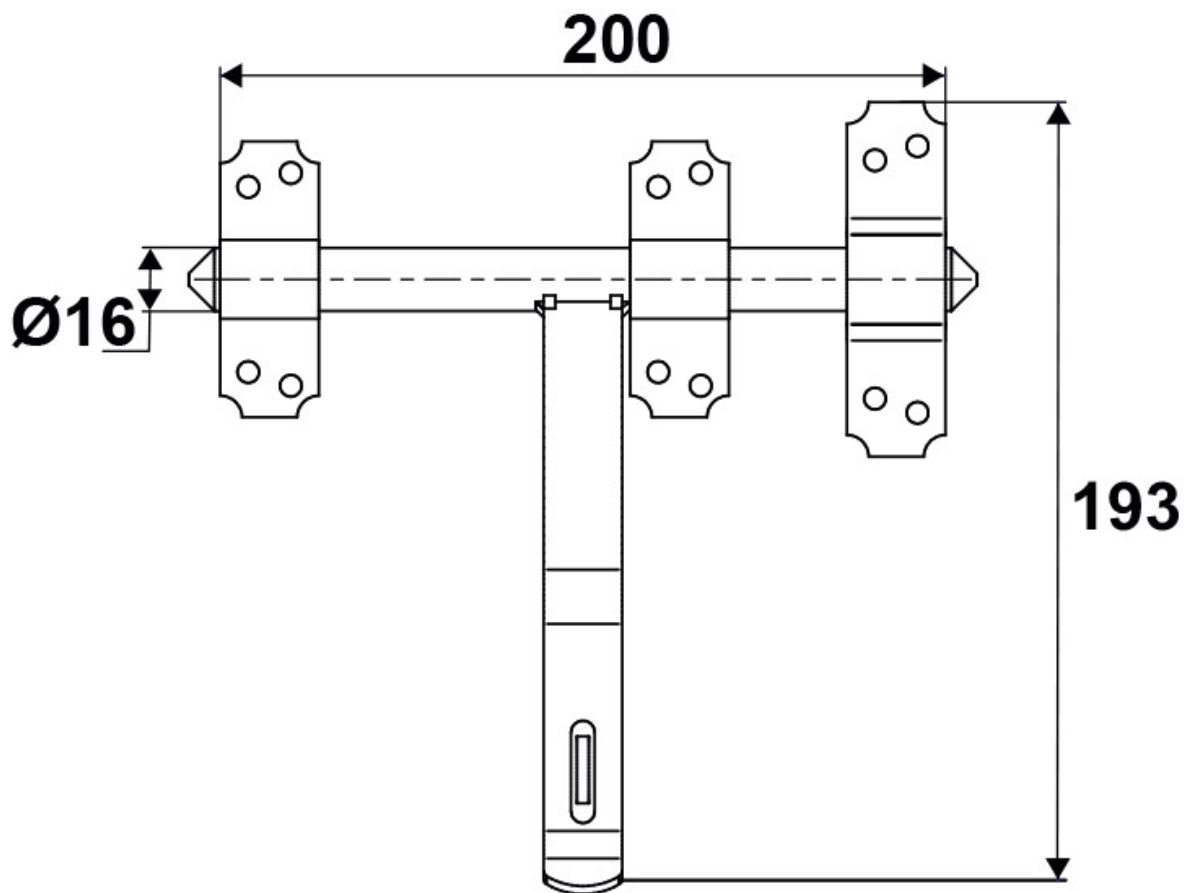

<https://www.qama.fr/verrou-vervelle-a-pattes-et-porte-cadenas-p3375>



Tel : 02 43 13 49 49

Fax : 02 43 30 26 16

www.qama.fr