

EMBASE À CADRE À VISSER 8099

HETTICH

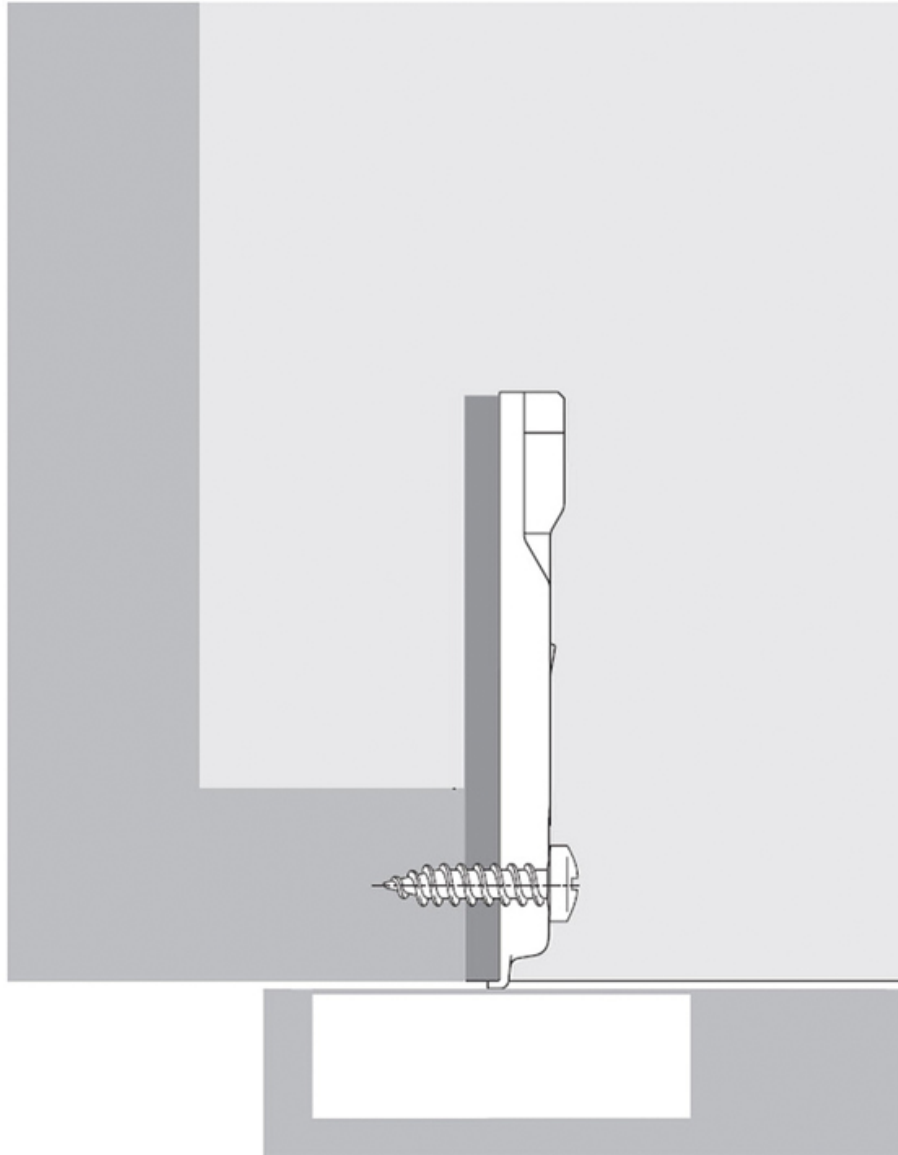

<https://www.qama.fr/embase-a-cadre-a-visser-p60786>



Tel : 02 43 13 49 49

Fax : 02 43 30 26 16

www.qama.fr

EMBASE À CADRE À VISSER 8099

HETTICH

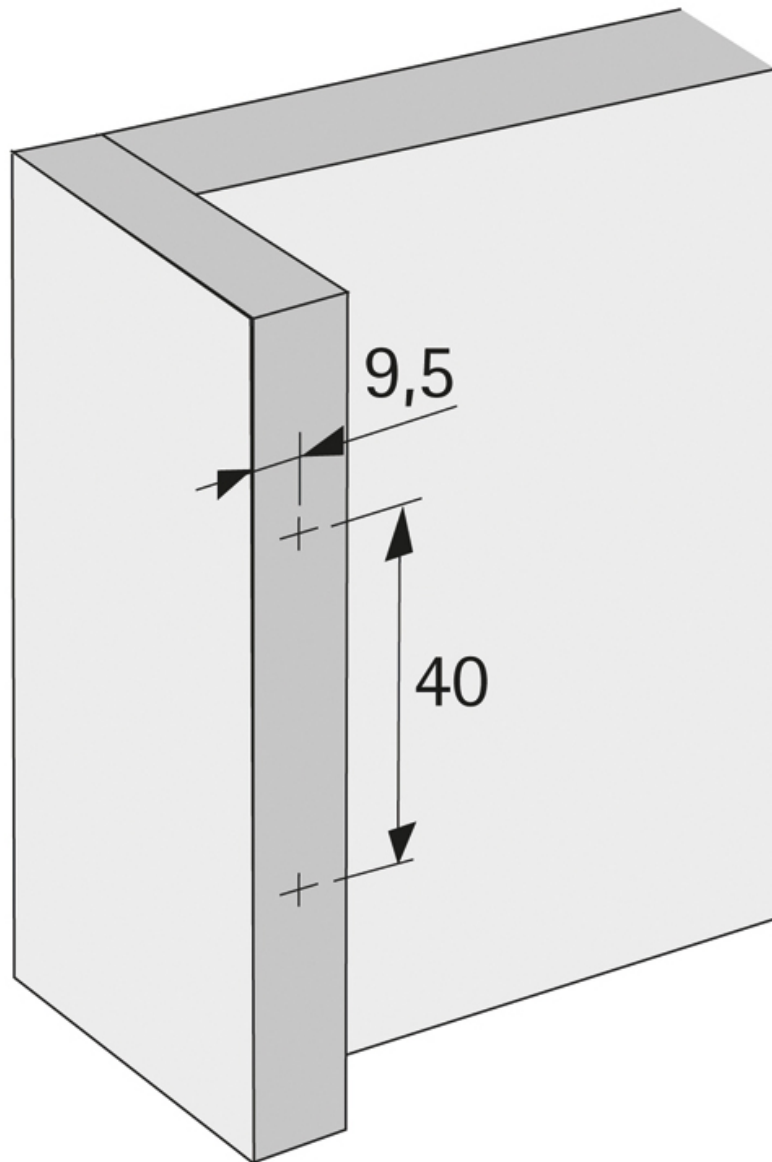

<https://www.qama.fr/embase-a-cadre-a-visser-p60786>



Tel : 02 43 13 49 49

Fax : 02 43 30 26 16

www.qama.fr